

Electrical Energy Meter with integrated Serial Modbus interface EEM400-D-MO

Electrical energy meter with an integrated Serial RS-485 Modbus interface allow direct reading of all relevant data, such as energy (total and partial), current and voltage for every phase and active and reactive power for every phase and for the three phases.

Main features

- 3-phase energy meter, 3 × 230/400 VAC 50 Hz
- Direct measurement up to 65 A
- Display of active power, voltage and current for every phase
- Display of active power for all phases
- Modbus RTU Interface to query the data
- Reactive power for every and/or all phases available through interface
- $\cos\varphi$ for every phases available through interface
- Up to 247 meters can be connected to the Modbus Interface
- 7-digits display for 1 or 2 tariffs
- Lead seal possible with cap as accessory
- Accuracy class B according to EN50470-3, accuracy class 1 according to IEC62053-21

Order Number

Standard Version: EEM400-D-MO
 MID Version: EEM400-D-MO-MID
 Sealing caps: EEM400-SEALCAP (Bulk with 20 units)

Technical Data

Precision class	B according to EN50470-3 1 according to IEC62053-21
Operating voltage	3 × 230 / 400 VAC, 50 Hz Tolerance -20%/+15%
Reference/maximum current	$I_{ref} = 10 \text{ A}$, $I_{max} = 65 \text{ A}$
Starting/minimum current	$I_{st} = 40 \text{ mA}$, $I_{min} = 0.5 \text{ A}$
Power consumption	Active 0.4W per phase
Counting range	00'000.00...99'999.99 100'000.0...999'999.9
Display	LCD backlit, digits 6 mm high
Display without mains power	Capacitor based LCD Max. 2 times over 10 days
Pulses per kWh	LED 1000 Imp./kWh



Mounting

Mounting	On 35 mm rail, according to EN60715TH35
Terminal connections Main circuit	Conductor cross-section 1.5 – 16 mm ² . screwdriver pozidrive no. 1 slot no.2, torque 1.5 – 2 Nm
Terminal connections Control circuit	Conductor cross-section max. 2.5 mm ² . screwdriver pozidrive no.0, slot no.2, torque 0.8 Nm
Insulation characteristics	4 kV/50 Hz test according to VDE0435 for energy meter part 6 kV 1.2/50 μs surge according to IEC255-4 2 kV/50 Hz test according to VDE0435 for Interface Device protection class II
Ambient temperature	-25°...+55°C
Storage temperature	-30°...+85°C
Environment	Mechanical M2 Electromagnetic E2
Relative humidity	95% at 25°...+40°C, without condensation
EMC/ interference immunity	Surge according to IEC61000-4-5 at main circuit 4 kV, at Modbus interface, 1 kV Burst according to IEC61000-4-4, at main circuit, 4 kV, at Modbus interface 1 kV ESD according to IEC61000-4-2, contact 8 kV, air 15 kV

Error display

Example: Connection error at L3

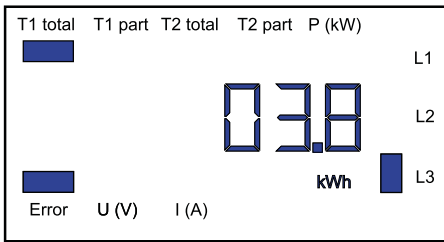

Example: Connection error at L1 and L3

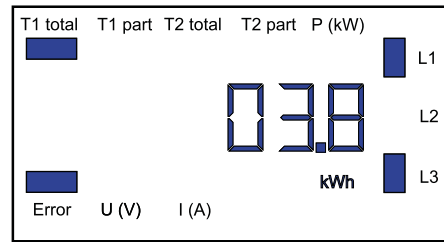

Dimension drawings

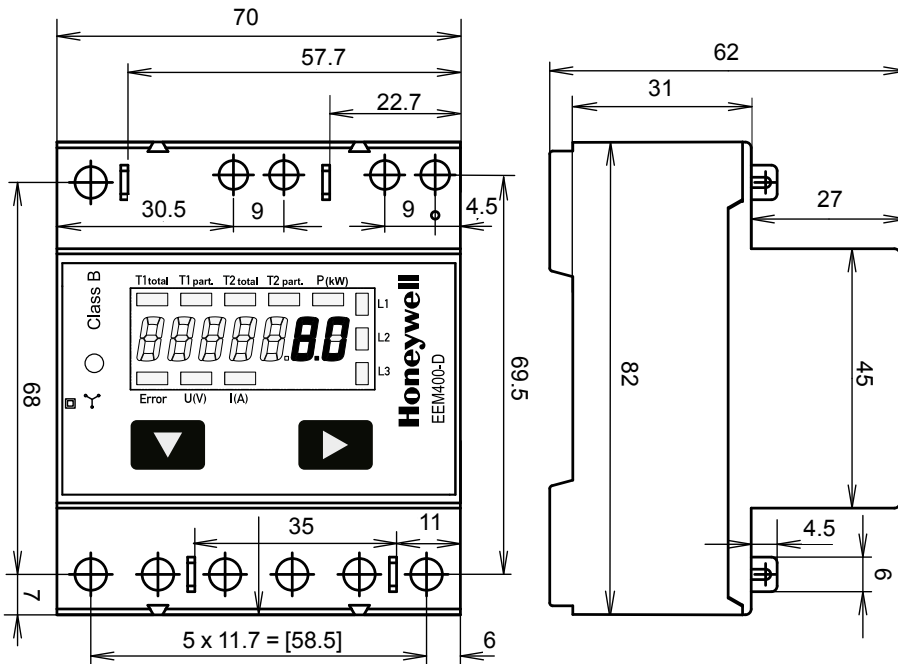

Display elements, direct measurement

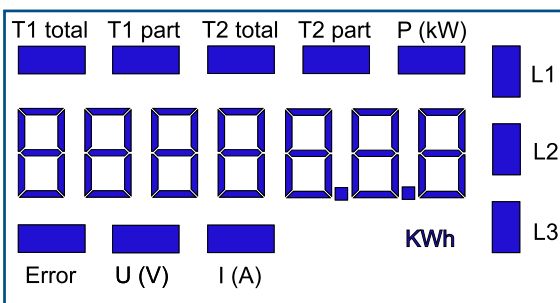

- **T1 total (kWh)** Shows the total consumption tariff 1
- **T1 part (kWh)** Shows the partial consumption for tariff 1, this value can be reset
- **T2 total (kWh)** Shows the total consumption tariff 2
- **T2 part (kWh)** Shows the partial consumption for tariff 2, this value can be reset
- **P (kW)** Shows the instantaneous power per phase or for all phases
- **U (V)** Shows the voltage per phase
- **I (A)** Shows the current per phase
- **kWh** Shows the unit kWh for consumption display
- **L1 / L2 / L3** For P, U, I or error message display, the corresponding phase is displayed
- **Error** In the absence of phase or incorrect current direction. The corresponding phase is also displayed.

Menu to display the values on the LCD

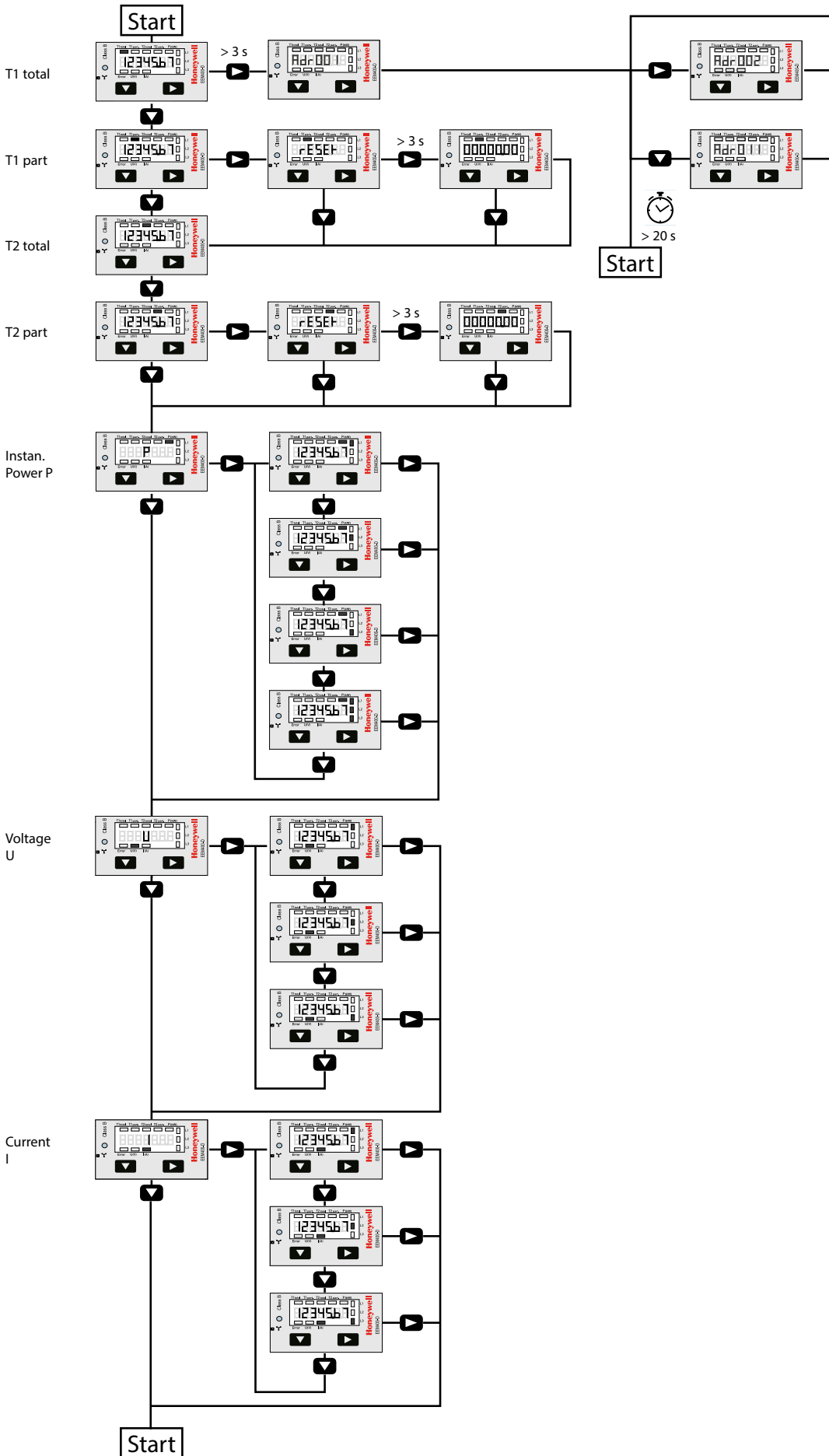

Wiring diagram

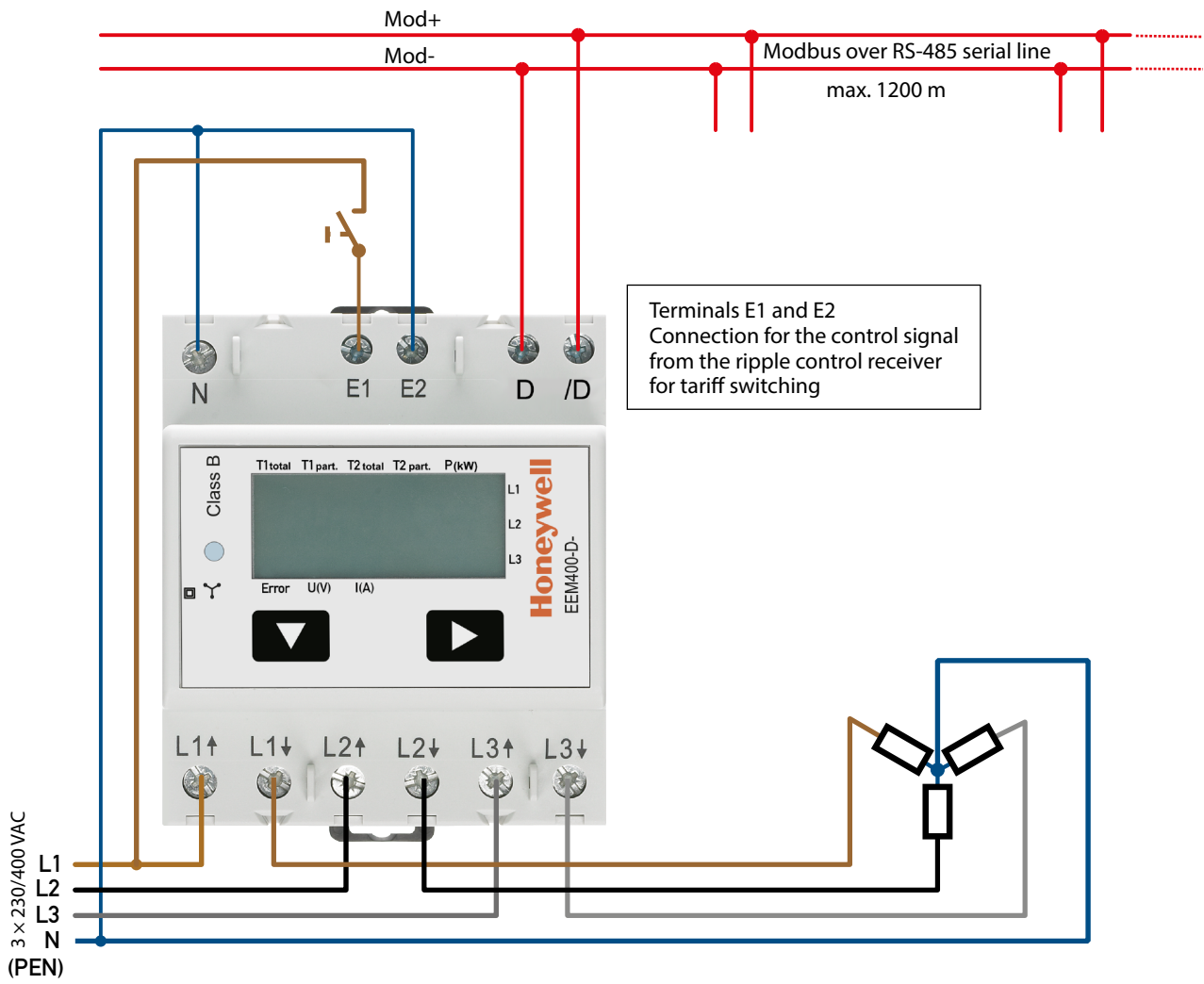

Technical data Modbus

Protocol	Modbus RTU according to IEC specification
Bus system	RS-485 serial line
Transmission rate (bps)	4800-9600-19'200-38'400-57'600-115'200. The transmission baud rate is automatically detected
Transmission mode	Even parity: 8 data bits, 1 stop bit Odd parity: 8 data bits, 1 stop bit No parity: 8 data bits, 2 stop bits The transmission Mode is automatically detected
Bus cable	Twisted, shielded, 2 × 0.5 mm ² , 1200 m max.
Response time (to system response)	Write: up to 60ms Read: up to 60ms

- The interface works only if the phase 1 is connected.
- The communication is ready 30 s after the 'Power On'.
- Refresh time for the data is 10 s. Therefore the delay between reads of the same data should be at least 10 s.
- The use of Energy meters in bus with intensive communication can increase the data refresh time.
- 247 devices can be connected to the Modbus. Over 128 devices, a repeater should be used.
- The interface don't have a terminal resistor, this should be provided external.
- For a description of the used registers please look at the 'Register Page'.

Data transmission

- Only «Read Holding Registers [03]/ Write Multiple Registers [16]» instructions are recognized.
- Up to 20 Registers can be read at a time.
- The device supports broadcast messages.
- In accordance with the Modbus protocol, a register R is numbered as R - 1 when transmitted.
- The device has a voltage monitoring system. In case of voltage loss, registers are stored in EEPROM (transmission rate, etc.)

Exception Responses

- ILLEGAL FUNCTION [01]: The function code is not implemented.
- ILLEGAL DATA ADDRESS [02]: The address of some requested registers is out of range or more than 20 registers have been requested.
- ILLEGAL DATA VALUE [03]: The value in the data field is invalid for the referenced register.

Change the Modbus address direct on device

- To modify the Modbus address, press 3 sec on ► touch
- In menu, ▼ increase address by 10, ► increase by 1
- Once the address is selected wait for the root menu to come back

Registers

For double registers (4–5, 16–17, 28–29, 30–31, 32–33, 34–35) the high register is sent first (big_Endian).
Partial counters (30–31, 34–35) can be reset by writing 0 in both registers in the same message.

R	Read	Write	Description	Unit
1	X		Firmware-Version	Ex: 11 = FW 1.1
2	X		Number of supported registers	Will give 52
3	X		Number of supported flags	Will give 0
4–5	X		Baudrate	Ex: Baudrate High = 1 Baudrate Low = 49'664 $1 \times 65'536 + 49'664 = 115'200$ bps
6	X		Not Used	Will give 0
7	X		Type / ASN function	Will give «EE»
8	X		Type / ASN function	Will give «M4»
9	X		Type / ASN function	Will give «00»
10	X		Type / ASN function	Will give «_-»
11	X		Type / ASN function	Will give «D-»
12	X		Type / ASN function	Will give «MO»
13	X		Type / ASN function	Will give « » for not MID or «-M» for MID Version
14	X		Type / ASN function	Will give « » for not MID or «ID» for MID Version
15	X		HW vers. Modif.	Ex: 11 = HW 1.1
16–17	X		Serial number Low	Unique ASCII serial number
18	X		Serial number High	Unique ASCII serial number
19	X		Not Used	Will give 0
20	X		Not Used	Will give 0
21	X		Not Used	Will give 0
22	X		Status / Protect	0 = no Problem 1 = problem with last communication request
23	X		Modbus Timeout	ms
24	X	X ¹⁾	Modbus Address	Range 1–247
25	X		Error register	0 : No error 1 : Error Phase 1 2 : Error Phase 2 3 : Error Phase 1 and 2 4 : Error Phase 3 5 : Error Phase 1 and 3 6 : Error Phase 2 and 3 7 : Error Phase 1, 2 and 3
26	X		Not Used	Will give 0
27	X		Tariff register	0 is Tariff 1 4 is tariff 2
28–29	X		WT1 total Counter Energy Total Tariff 1	10^{-2} kWh (multiplier 0,01) Ex: WT1 total High = 13 WT1 total Low = 60'383 $13 \times 65'536 + 60'383 = 912'351 = 9123.51$ kWh
30–31	X	X	WT1 partial Counter Energy Partial Tariff 1	10^{-2} kWh (multiplier 0,01) Ex: WT1 partial High = 13 WT1 partial Low = 60'383 $13 \times 65'536 + 60'383 = 912'351 = 9123.51$ kWh
32–33	X		WT2 total Counter Energy Total Tariff 2	10^{-2} kWh (multiplier 0,01) Ex: WT2 total High = 13 WT2 total Low = 60'383 $13 \times 65'536 + 60'383 = 912'351 = 9123.51$ kWh
34–35	X	X	WT2 partial Counter Energy Partial Tariff 2	10^{-2} kWh (multiplier 0,01) Ex: WT2 partial High = 13; WT2 partial Low = 60'383 $13 \times 65'536 + 60'383 = 912'351 = 9123.51$ kWh
36	X		URMS phase 1 Effective Voltage of Phase 1	V Ex: 230 = 230 V

37	X		IRMS phase 1 Effective Current of Phase 1	10^{-1} A (multiplier 0,1) Ex: 314 = 31.4 A
38	X		PRMS phase 1 Effective active Power of Phase 1	10^{-2} kW (multiplier 0,01) Ex: 1545 = 15,45 kW
39	X		QRMS phase 1 Effective reactive Power of Phase 1	10^{-2} kvar (multiplier 0,01) Ex: 1545 = 15,45 kvar
40	X		cos phi phase 1	10^{-2} (multiplier 0,01) Ex: 67 = 0,67
41	X		URMS phase 2 Effective Voltage of Phase 2	V Ex: 230 = 230 V
42	X		IRMS phase 2 Effective Current of Phase 2	10^{-1} A (multiplier 0,1) Ex: 314 = 31.4 A
43	X		PRMS phase 2 Effective active Power of Phase 2	10^{-2} kW (multiplier 0,01) Ex: 1545 = 15,45 kW
44	X		QRMS phase 2 Effective reactive Power of Phase 2	10^{-2} kvar (multiplier 0,01) Ex: 1545 = 15,45 kvar
45	X		cos phi phase 2	10^{-2} (multiplier 0,01) Ex: 67 = 0,67
46	X		URMS phase 3 Effective Voltage of Phase 3	V Ex: 230 = 230 V
47	X		IRMS phase 3 Effective Current of Phase 3	10^{-1} A (multiplier 0,1) Ex: 314 = 31.4 A
48	X		PRMS phase 3 Effective active Power of Phase 3	10^{-2} kW (multiplier 0,01) Ex: 1545 = 15,45 kW
49	X		QRMS phase 3 Effective reactive Power of Phase 3	10^{-2} kvar (multiplier 0,01) Ex: 1545 = 15,45 kvar
50	X		cos phi phase 3	10^{-2} (multiplier 0,01) Ex: 67 = 0,67
51	X		PRMS total Effective active Power of all phases	10^{-2} kW (multiplier 0,01) Ex: 1545 = 15,45 kW
52	X		QRMS total Effective reactive power of all phases	10^{-2} kvar (multiplier 0,01) Ex: 1545 = 15,45 kvar

¹⁾ The Modbus Address register is not writable with a broadcast message.

Honeywell

Manufactured for and on behalf of the Environmental and Combustion Controls Division of Honeywell Technologies Sàrl, Rolle, Z.A. La Pièce 16, Switzerland by its Authorized Representative:

Saia-Burgess Controls AG
Bahnhofstrasse 18
CH-3280 Murten / Switzerland

Phone +41 26 580 30 00
Fax +41 26 580 34 99

Subject to change without notice. Printed in Switzerland
PP26-594 ENG03 07.2015