

DUCT PARTICULATE MATTER SENSOR

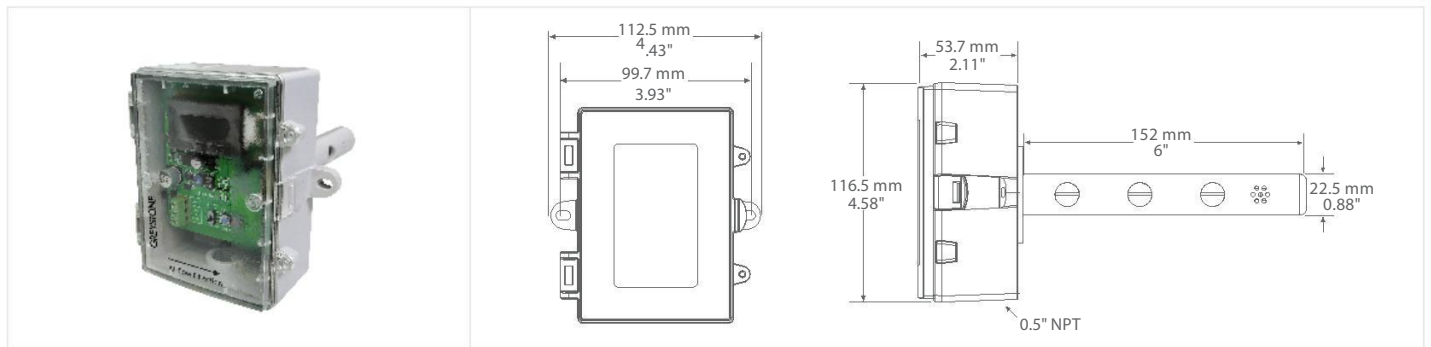

PMDT SERIES

PRODUCT DESCRIPTION

The PMDT Duct Particulate Matter Sensor uses an optical sensor based on laser scattering principles and features innovative contamination resistance technology to perform highly accurate and reliable PM measurements. The replaceable sensor measures particles of PM1.0, PM2.5, PM4.0, or PM10, with a continuous operation lifetime of more than 8 years. The sensor will provide long-term reliability and high resolution particle size binning for the detection of environmental dust and other particles. A hinged and gasketed Polycarbonate enclosure is included for ease of installation.

TYPICAL INSTALLATION

For complete installation and wiring details, please refer to the product installation instructions.

The duct type sensor installs on the outside of a return air duct with the sampling tube inserted into the duct. Mount the sensor in an easily accessible location in a straight section of duct at least five feet from corners and other items that may cause disturbances in the air flow. Avoid areas with vibrations or rapid temperature changes. The duct sensor must be mounted in proper direction of air flow.

The enclosure provides mounting tabs for ease of installation.

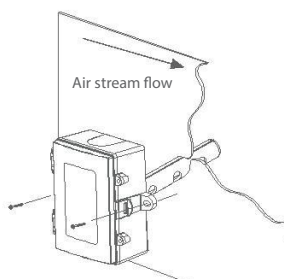

SPECIFICATIONS

SENSOR	Laser scatter method (field replaceable)
PARTICULATE SIZE	PM1.0, PM2.5, PM4.0, or PM10 (selectable)
MASS CONCENTRATION RANGE	0 - 1000 ug/m ³
RESOLUTION	1 ug/m ³
ACCURACY	±10 ug/m ³ (0 - 100 ug/m ³), ±10% (100 - 1000 ug/m ³)
RESPONSE TIME	1 second
SENSOR LIFETIME	>8 years
ANALOG MODEL	Consumption: 75 mA max @ 24 Vdc, 100 mA max @ 24 Vac Output Signals: 4-20 mA (sourcing) or 0-5 Vdc / 0-10 Vdc (selectable) Output Drive Capability: Current - 550Ω max Voltage - 5,000Ω min Output Scale: 0 to 1000 ug/m ³ (menu selectable)
BACnet® MODEL	Consumption: 50 mA max @ 24 Vdc, 80 mA max @ 24 Vac Interface: MS/TP, 2 wire RS-485 Baud Rate: 9600, 19200, 38400, 57600, 76800 or 115200 (menu selectable) Address Range: 0 - 127 (menu selectable)
MODBUS MODEL	Consumption: 50 mA max @ 24 Vdc, 80 mA max @ 24 Vac Interface: MS/TP, 2 wire RS-485, RTU Baud Rate: 9600, 19200, 38400, 57600, 76800 or 115200 (menu selectable) Address Range: 1-255 (menu selectable)
TRI-COLOR LED	Good: Green (0 to 50 ug/m ³) Moderate: Yellow (51 to 150 ug/m ³) Poor: Red (151 to 1000 ug/m ³)
PM ALARM RELAY (OPTIONAL)	Contact Ratings: Form C (NO + NC), 2A @ 140 Vac, 2A @ 30 Vac Setpoint + Hysteresis: Programmable via menu Relay Time Delay: Programmable via manu
LCD SIZE	35mm W x 15mm H (1.4" x 0.6")
LCD BACKLIGHT	Enable or disable via menu
DISPLAY VALUE	Mass Concentration: 0 - 1000 ug/m ³ Air Quality Index: 0 - 500 AQI Good/Moderate/Poor (menu selectable)
POWER SUPPLY	24 Vac/dc ±20% (non-isolated half-wave rectified)
PROTECTION CIRCUITRY	Reverse voltage protected, over-voltage protected
OPERATING CONDITIONS	-10 to 60°C (14 to 140°F), 20 to 80 %RH non-condensing
STORAGE CONDITIONS	-40 to 70°C (-40 to 158°F)
ENCLOSURE	Material: Polycarbonate, Grey, UL95-V0, IP65, (NEMA 4X) Dimensions: 116mm W x 100mm H x 54mm D (4.6" x 3.9" x 2.1") Probe: 22.5mm D x 152mm L (0.88" x 6")
WIRING	Screw terminal block (14 to 22 AWG)
COUNTRY OF ORIGIN	Canada

WIRING INFORMATION

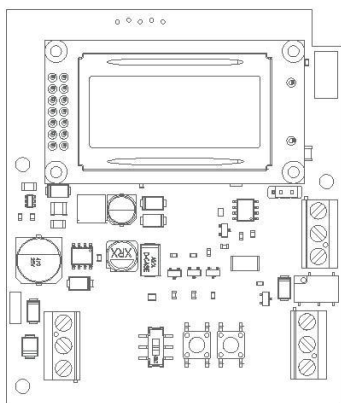

TERMINAL	FUNCTION
PWR	+ 24 Vdc/24 Vac (HOT)
COM	Common
OUT	Analog Output
NO	Relay Normally Open Contact
R. COM	Relay Common
NC	Relay Normally Closed Contact

If BACnet® or Modbus Output Selected

B(+)	Network Output
A(-)	Network Output
SHLD	Network Output

ORDERING

PRODUCT	PMDT	Duct Particulate Matter Sensor
ENCLOSURE	B F	Polycarbonate with hinged and gasketed cover Same as B, with thread adapter (1/2"NPT to M16) and cable gland fitting
RELAY	X R	None Alarm Relay
OUTPUT	X B M	Analog Output Only BACnet® and Analog Outputs Modbus and Analog Outputs

NOTE: Greystone Energy Systems, Inc. reserves the right to make design modifications without prior notice.

ACCESSORIES	PMFRSM	Replaceable sensor module and wire harness

PART NUMBER

PMDT

Honeywell

Hergestellt für und im Namen der Connected Building Division of Honeywell Technologies Sàrl, 1180 Rolle, Z.A. La Pièce 16, Schweiz, durch ihre autorisierte Vertreterin:

Honeywell GmbH
Hans-Klemm-
Strasse 5
71034 Böblingen
Deutschland